

**PRIMULA<sup>®</sup> S.A.**

**IRONING PRESSING MACHINERIES - FUSING  
PRESSES**

**Instruction Manual  
Steam generator series Ecovapor**

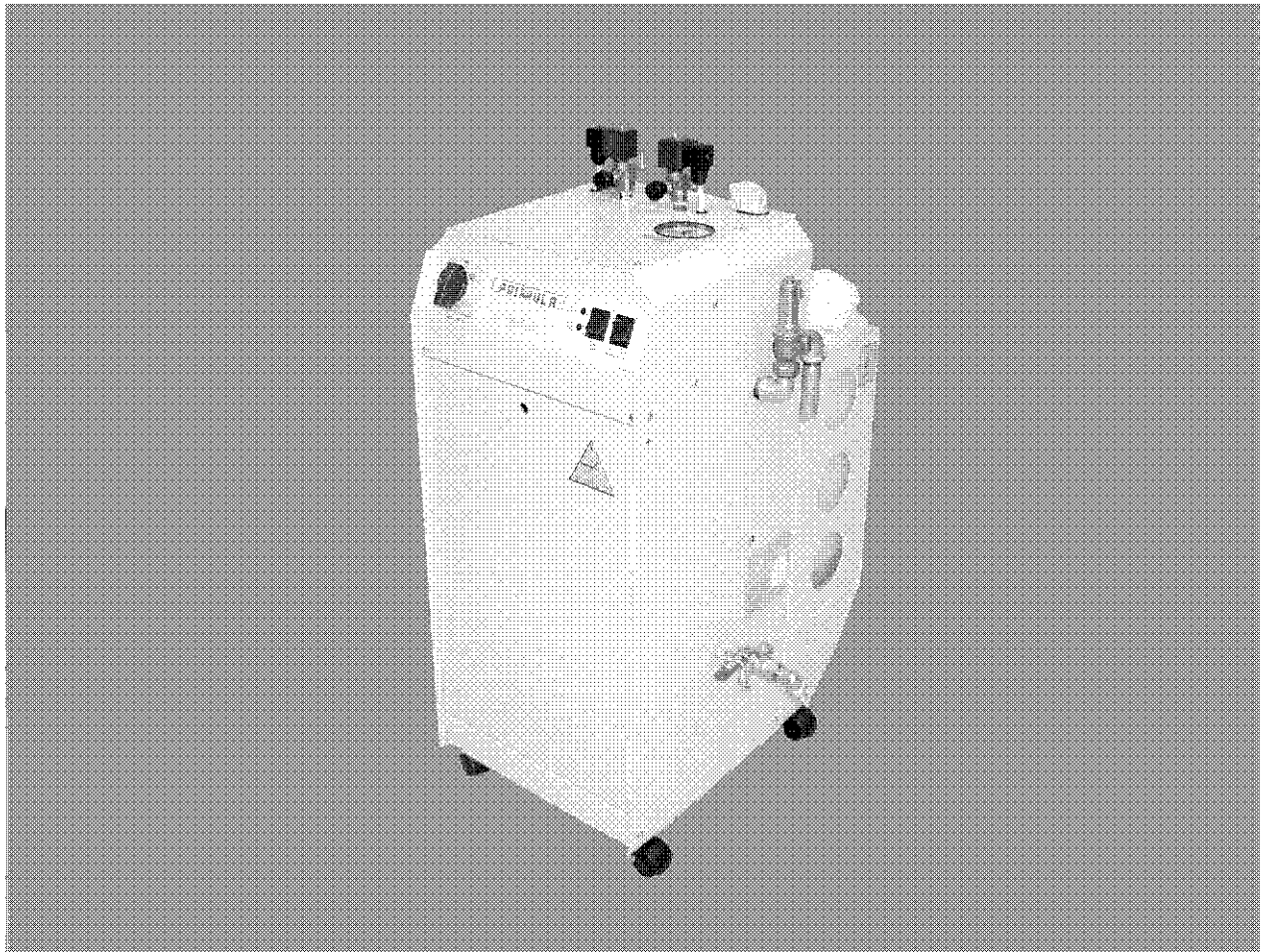



## Models - Technical specifications

Model	Ecovapor/1-2,5	Ecovapor/1-4	Ecovapor/2-4	Ecovapor/2-4
Heating capacity	2,5KW	4KW	4KW	4KW
Steam outlets	1	1	2	2
Steam capacity	3,25kg/h	5,2kg/h	5,2kg/h	5,2kg/h
Power supply	230V-1ph-50Hz	230V-1ph-50Hz	230V-1ph-50Hz	400V-3ph-50Hz
Steam pressure	3,5 bar	3,5 bar	3,5bar	3,5bar
Packing Dim.	54X59X99cm	54X59X99cm	54X59X99cm	54X59X99cm
Net Weight	53kg	53kg	53kg	53kg
Gross Weight	58kg	58kg	58kg	58kg
Code	103-06-004	103-06-003	103-06-001	103-06-002

### For all 4 models

Normal working pressure	3,5 bars
Max working pressure	4,2 bars
Admissible design pressure	6,2 bars
Steam temperature 3,5bars	149 °C
Electric connections	Neutral wire and earth wire separate according to VDE Regulations
Boiler capacity	8,5lt
Max. boiler's water capacity	4lt
Min. boiler's water capacity	3,5lt
Wiring according to European Specifications	Blue-Neutral wire Green/yellow-earth wire Brown or black-phase
Feeding-water tank	25lt
Condensate tank	10lt
Heating-up time	Ca 15-20 minutes

**CAUTION! PLEASE READ CAREFULLY THE INSTRUCTION MANUAL BEFORE INSTALLING THE STEAM GENERATOR!!!**

All specifications have been made to the best of our knowledge.  
Specifications may be subject to change without any prior notice.

## **A few words by the manufacturer**

The steam generator "Ecovapor" is a machine of high advanced technology with many advantages, unique in its kind. It is manufactured according to International and European safety standards by a company with experience ,since 1969, in this sector. Congratulations for your choice!

### **Remarkable advantages!**

- Operation through main switch.
- Built-in electric water pump, amplified against pressure, with thermal protection.
- Electrical circuit consisted by silicon wires.
- Ground wire to all electrical parts.
- Blocking system on the water outlet valve for more safety against any burning.

### **Installation**

The machine is ready to work. Just place it to the requested position and connect it to the power.

The good operation of the machine is depended on the feedwater formation.

#### Feedwater requirements:

Hardness	less than 100mg/las CaCO or less than 6 German degrees
PH	7-8
CO	No free CO allowed.
TDS	less than 200mg/l.
Fe	None
Suspended solids	Water should be clear and free from suspended solids, colloids, alcal, ect.

### **Electrical connection**

For the electrical connection and everything about the power supply, follow carefully the instructions of the wiring diagram(enclosed). Pay attention to the WARNING symbols, attached to the machine. Connect the machine to the power supply through the plug No 25 . If power supply is 230Volt/1phase, the connection must be done ,in a 3-poles socket plug (1 phase, 1 neutral, 1 ground). The power must be insured by a 2-poles (25 Amber) fuse.

**CAUTION!**The manufacturer denies any liability for any injury or accident that might be caused due to faulty power networks or due to faulty connections made by unskilled persons.

**\* Attention !**

- Any thermal intervention or welding to the boiler No 1, without being advised by the manufacturer, is **strictly forbidden**.

(In that case, the manufacturer does not have any responsibility).

- Any modification to the technical specifications of the machine(electrical or mechanical) is **strictly forbidden** to the third persons.

(In that case the manufacturer does not have any responsibility).

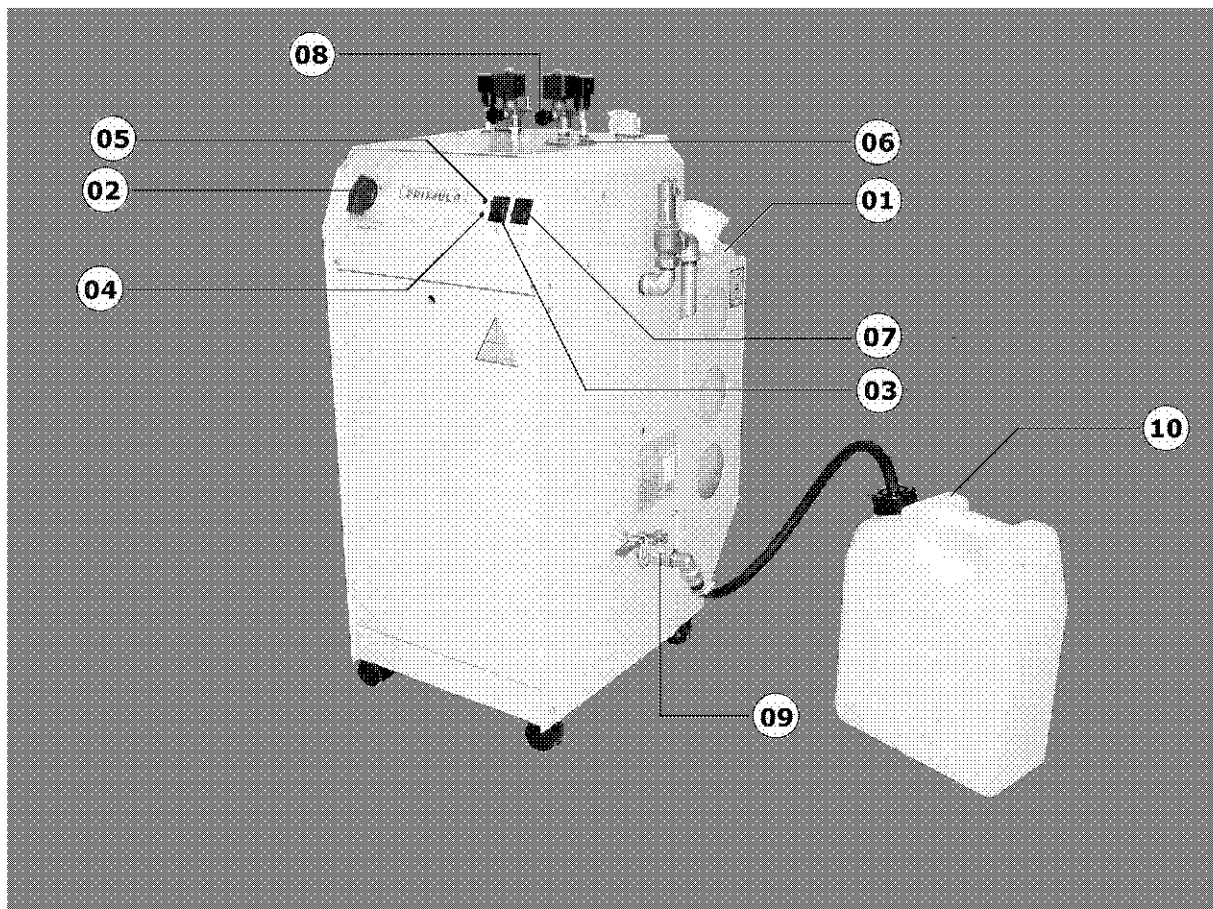

**Operating instructions**

Fill the feedwater tank of 25lt(No 01) with clear water, using preferably soft water (up to 8 dh hardness). Turn on the main switch(No 02). Press the button No 03 .The water pump starts to feed water into the boiler and the lamp No 04 is on. The steam lamp No 05 will be lighted after a while.During operation the boiler refills automatically.

Within a few seconds the boiler starts heating the water in order to supply steam in about 15-20 min. The manometer(No 06) should reach 3,5 bars. The machine is ready to work.Press the irons button(s)(No 07 ), only one button if the requested produced steam is for 1 steam iron, or both buttons if the requested produced steam is for 2 steam irons.(That depends on whether you have Ecovapor for steam supply for one or two irons). Adjust the temperature of the iron using the thermostat knob, according to the

fabric requirements. Adjust the steam quantity by the adjustor knob (No 08 ) according to the fabric requirements. You can start ironing!

### **CAUTION !**

- The first time you press the iron's microswitch to flow steam you may have a steam liquidation, due to the cold condition of the iron's steam hose. So please press 2-3 times the microswitch away from the working surface until only clean dry steam flows out.
- Before you start working, make sure that the water feeding vessel of the machine, is filled.
- In case the pump runs unusually noisily for quite long period of time, the feedwater tank may be empty or the filling hose may be clogged.

### **After you finishing working**

- Switch off the iron buttons No 07.
- Turn off the main switch No 02
- Turn on slowly the outlet valve No 09 to remove the water deposited in the boiler.

**WARNING !** To avoid any burning accident ,follow carefully the instructions below:  
Fill the condensate vessel C(sketchd below) by water,at a level of 5 cm.approximately. Screw tightly cap D.Unlock safety blocker A.Turn on slowly the outlet valve B (No 09) to remove any water condensates from the boiler.After finishing, turn off outlet valve B and lock again safety blocker A.

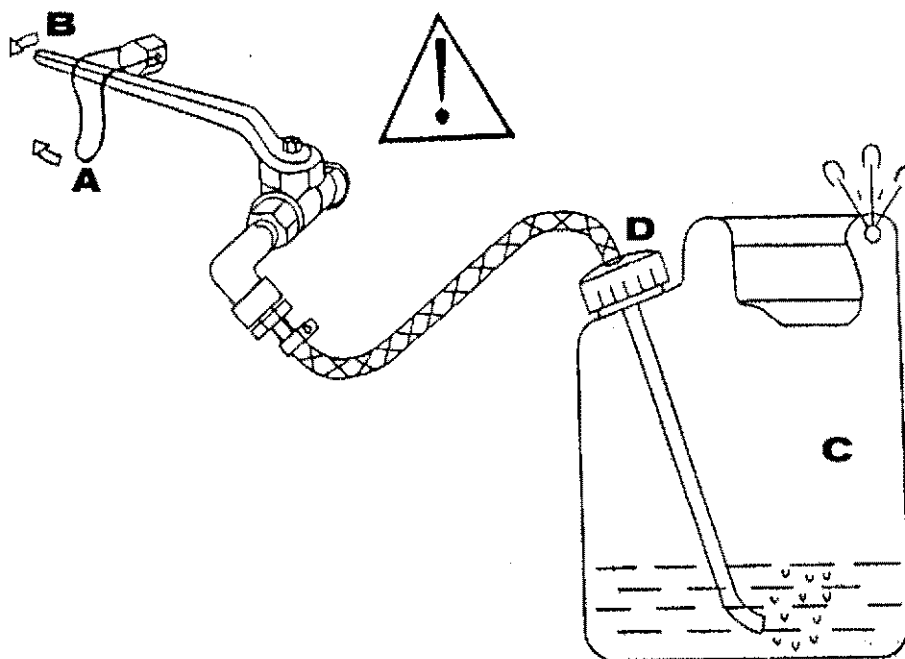

### **Test the good operation of the machine :**

Remove a small quantity of water (0,5lit.approx.) of the boiler, by turning on slowly the outlet valve No 09.The pump is activated automatically in order to feed the boiler by the lost quantity of water. When the pump stops, turn off outlet valve No 09.Wait for a few minutes .When the manometer No 06 reaches 3,5 bars, the machine is ready to work.This procedure must be periodically repeated.

### **Maintenance**

- Keep the machine as clean as possible.
- Clean the inside of the machine by compressed air ,at least 2 times per year. (Depends on the quality of the water).
- Periodically clean the electrode No 16 from deposited salts ,and pay attention on its replacement. (See the correct position on the enclosed wiring diagram).
- Periodically check if the links of the water and steam pipes have leaks.
- When the heating element No 23 has to be replaced, take the chance to clean the salts of the inside of the steam boiler No 22 , by a pointed instrument.
- When you keep the machine out of operation for a long period of time, leave the steam boiler Nr 22 filled with water to avoid boiler's inside oxidation .

### **Troubles shooting**

#### **The pump does not run:**

- Check the responding fuse for pump on the electronic PC board typ.ECO 903No33
- Check if the voltage of the power supplied to the pump No 21 is 230V.
- Check if the pump is stuck off due to salts –this usually happens when the pump is out of work for a long period time - Shooting :Turn the Pivot of the pump by putting a screwdriver through the hole at the back side of the machine which leads to the pump.
- Check if the pump is clogged.

#### **The water is not heated while the steam lamp lights on.**

- Check the fuse(1Amber) which is used for the heating on the electronic circuit card
- Check the relay which is used for the heating on the Electronic circuit card.
- Check the Pressure switch No 15 (symbol PS on the wiring diagram)
- Check the relay K1(symbol on the wiring diagram)

#### **The steam iron is not heated while the iron lamp lights on:**

- Check the fuse (25Amber) according to the wiring diagramm.
- Check the iron itself, the cabel, the thermostat etc.

**If the iron is heated normally but it does not blow steam check the coil 12W/230V of the solenoid steam valves No 38 (EV1, EV2 on the wiring diagram) as well as the steam microswitch of the iron.**

**If the boiler is overfilled and the iron blows steam & water**

- Check electrode E1 No16:clean or replace it.
- Check solenoid water valve No30: clean or replace it.
- Check if the water control system on the Electronic circuit card No32 is running normally. If not, replace it.

**If the pump is ordered to feed water in very short periods & steam draining is appeared in the feed-water tank No 1, check the one way valve No29:Clean or replace it , by paying attention on putting it back in the correct direction.**

**SAFETY VALVE**

If it remains open –the manometer No 06 shows over 3,5bar.Check the pressure switch pressure adjustment. Adjust it at max. 3,5bar. In case it continues increasing,please replace the pressure switch No 15.

**Technical Assistance**

For any advice about the operation of the machine or the spare parts, please contact our agents in your territory-----  
-----  
-----  
-----

or directly us.



27, Olimpou str.- 546 30 Thessaloniki - Greece  
Tel.: +30 2310 541985/6 Fax : +30 2310 513076  
E-mail : [info@primula.gr](mailto:info@primula.gr)

**-Specifications may be subject to change without prior notice.**



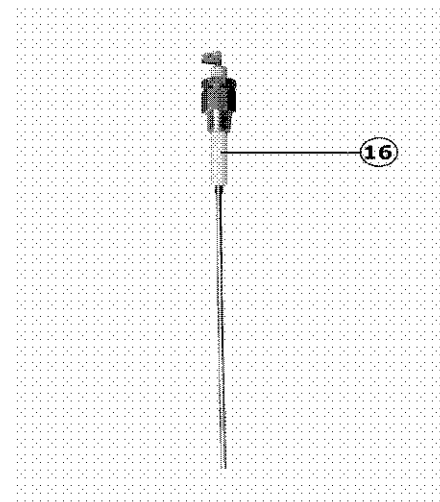
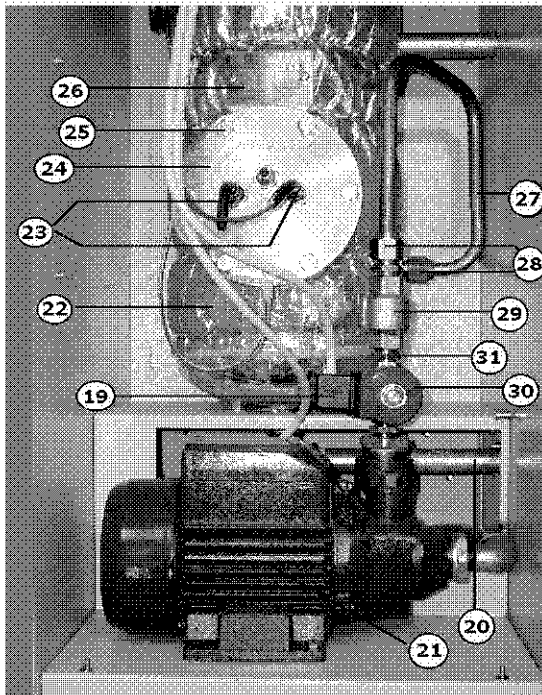
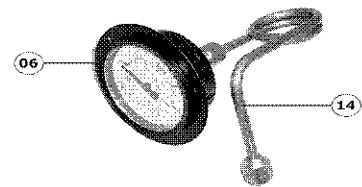
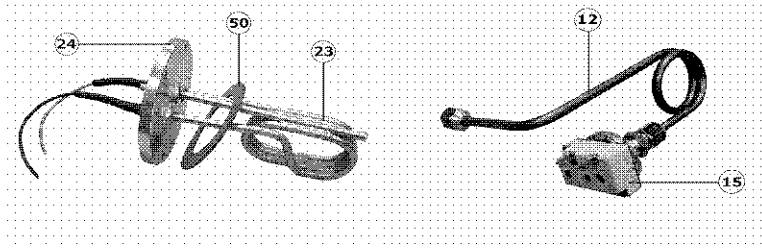
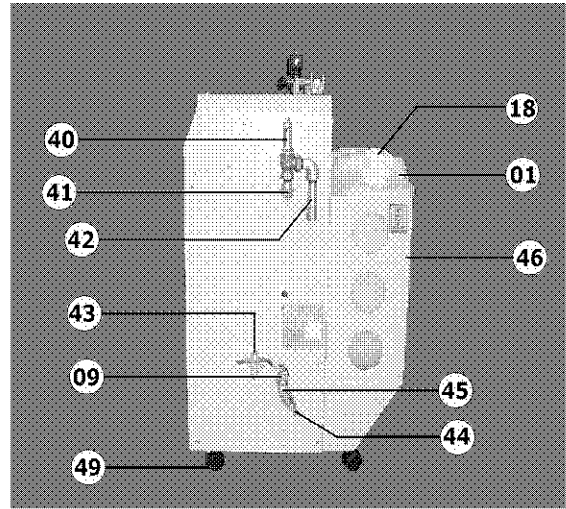
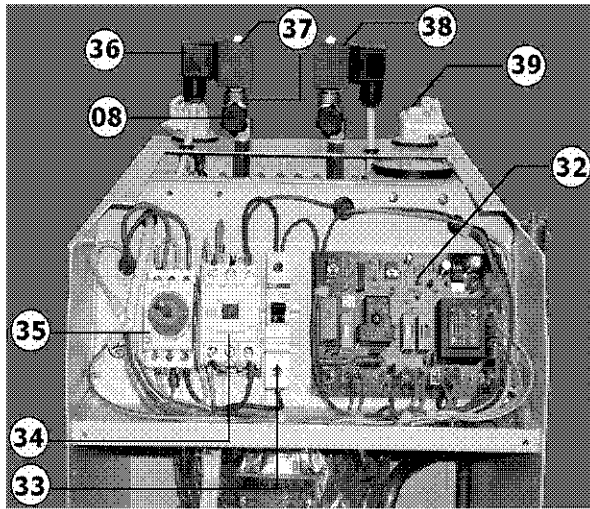
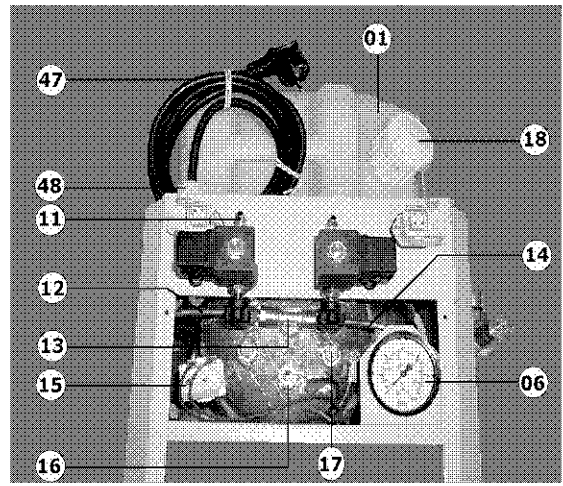
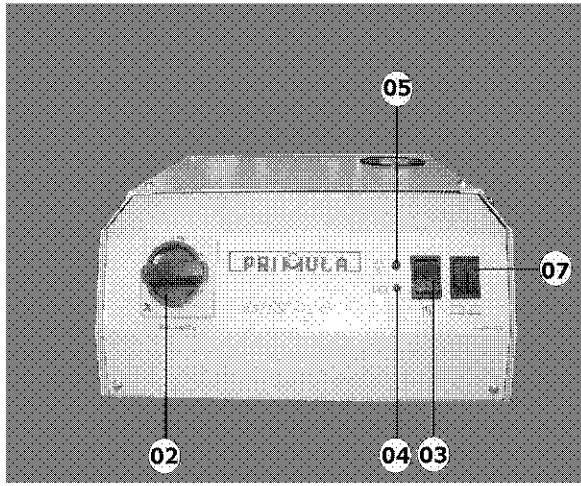

**Steam generator mod. Ecovapor - Spare parts list**

<b>Pos.</b>	<b>Articel nr.</b>	<b>Designation</b>
1	303-03-041	Feedwater tank 25lt
2	303-03-031	Cover of main switch KATKO
3	308-00-006	Switch ON-OFF 16A
4	303-06-004	Control lamp red (LED)
5	303-06-004	Control lamp red (LED)
6	303-03-007	Manometer
7	302-00-017	Double switch ON-OFF
8	308-00-005	Knob of solenoid steam valve
9	303-03-026	Blow-down valve 1/2"
10	303-03-039	Blow-down tank
11	308-00-004	Corner of solenoid steam valve
12	103-06-012	Pressostat's coil
13	303-06-013	T 1/4"-1/4"-1/4"
14	193-06-014	Manometer's coil
15	303-03-014	Pressostat
16	193-06-016	Electrode
17	303-06-017	Electrode's plug
18	303-06-018	Feedwater tank's lid
19	308-00-003	Valve's plug
20	193-06-020	Condensate's pipe
21	303-06-002	Water pump 0,5HP PKM60
22	303-03-001	Boiler
23	303-03-003-1	Heating element 4000W/230V with case
24	303-06-024	Metallic flange of heating element
25	303-06-025	Heating element's screw
26	193-06-026	Boiler's number
27	193-06-027	Water's copperpipe 1/2"
28	303-06-028	Nipple 1/2"
29	303-03-016	One-way valve 1/2"
30	303-03-018	Solenoid water valve 3/8" 9313
31	303-06-031	Nipple 1/2" X 3/8"
32	303-06-032	Electronic PC board
33	303-06-033	Fuse 25A of heating element
34	303-03-032	Relay of heating element
35	302-03-038	Main switch 3X25Amber
36	308-00-003	Valve's plug
37	303-02-014	Solenoid steam valve
38	303-06-038	Coil of solenoid steam valve 6724
39	303-03-021	Female plug-4 poles ILME
40	303-03-011	Safety valve 1/2" BETA
41	303-03-017	Corner 1/2" (Male-Female)
42	193-06-042	Pipe of safety valve 1/2" BETA
43	303-03-033	Safety hanger BALL VALVE

44	303-03-023	Nipple 1/2" X 9
45	303-03-027	Corner 1/2" (Male-Female) of blow-down valve
46	193-06-046	Water-feed tank's base
47	303-03-025	Power feeding cable 3X2,5mm <sup>2</sup> with Shuko plug
48	303-06-048	Gland
49	303-03-029	Double wheel
50	303-03-004	Seal heating flange

# PRIMULA

## ELECTRIC WIRING

### ECO VAPOR 2-4

#### 400V 50-60Hz

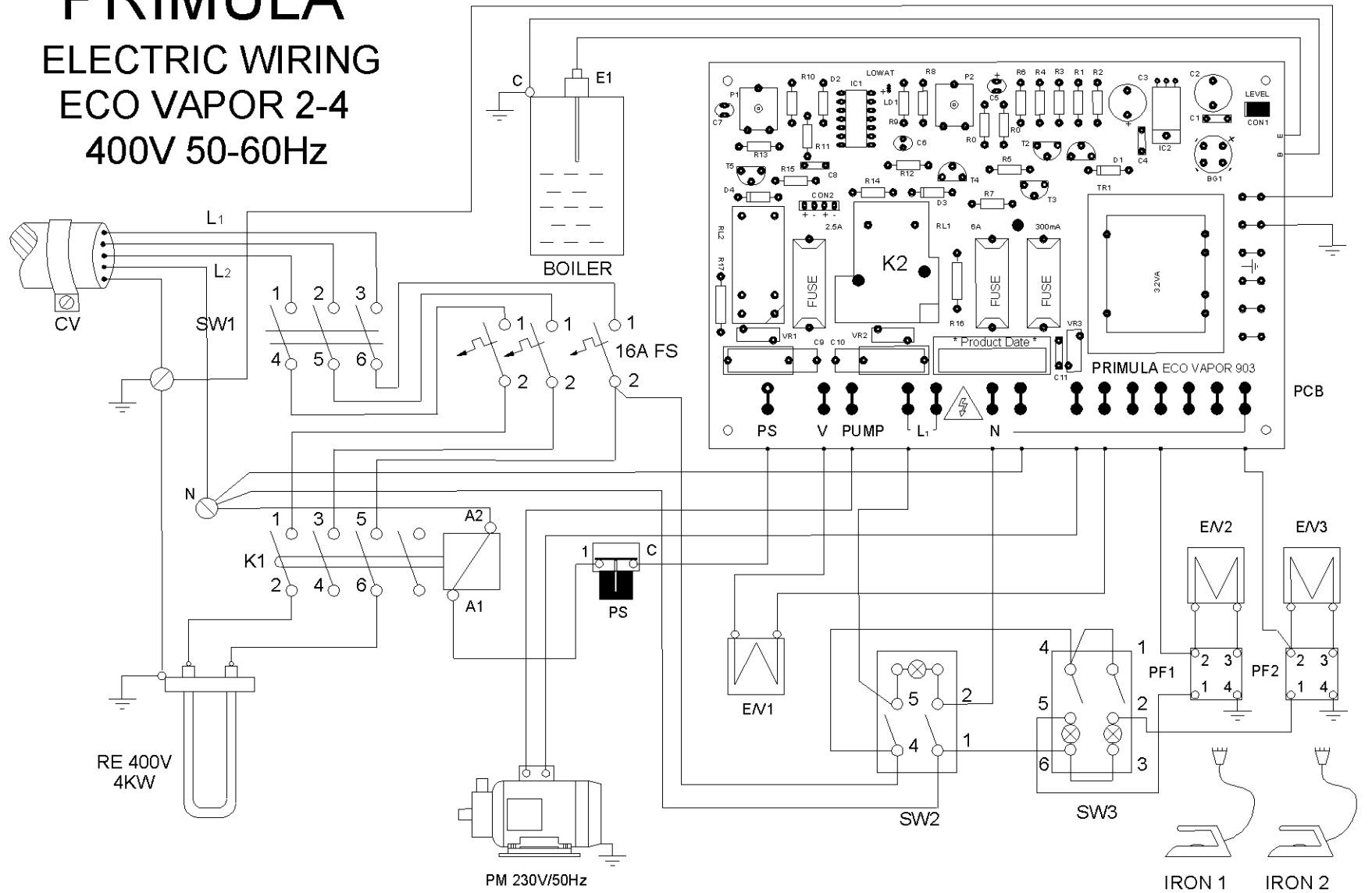

## WIRING DIAGRAM – STEAM GENERATOR ECOVAPOR

Symbol	Code	Description
SW1	302-03-038	Main switch 3X25A
K1	303-03-032	Relay for heating 25A-230V
K2	303-03-036-3	Relay for pump 30A on the Electronic circuit card typ.903
RE	303-03-003-9	Heating element 4KW,400V
PS	303-03-014	Pressostat
PF1	303-03-021	Socket plug for iron No 1
PF2	303-03-021	Socket plug for iron No 2
E/V1	303-03-018	Solenoid water valve
E/V2	303-02-014	Solenoid steam valve No 1
E/V3	303-03-010	Solenoid steam valve No 2
PM	303-06-002	Water pump 0,5HP 230V-1ph.
E1	303-06-016	Water level electrode
PCB	302-26-001	Electronic circuit card -all functions control ,typ ECO 903
CV	303-03-025-1	Cabel of power supply 5X2,5mm <sup>2</sup>
FS	303-06-033	Automatic fuse 25A